

# EVAK STAINOX 5.50

## 316 SS submersible for dirty water and sewage

Available in 400/3/50 the cast 316 stainless steel Stainox submersible pump has been designed for arduous contaminated water and sewage type applications.

It features a vortex impeller providing a 45mm dia. solids handling capability.

- Nominal 3.7kW (5HP) • Klixon Protection
- Nominal 7.5 Amp • 3" BSPF discharge elbow
- 2850 RPM 2 Pole • Oil Chamber with Viton Oil Seal
- Double Mechanical Seal - Ca/Ce+Sic/Sic
- Cast 316 SS construction • 316 SS handle
- Sheet 316 Motor Housing • Weight only 56 Kg.
- 10 metre H07RN-F cable as standard
- Models to Max. 30mH/21l/s available to order

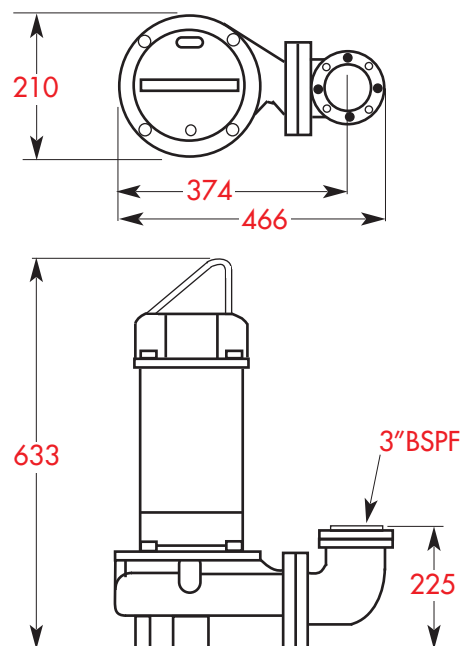
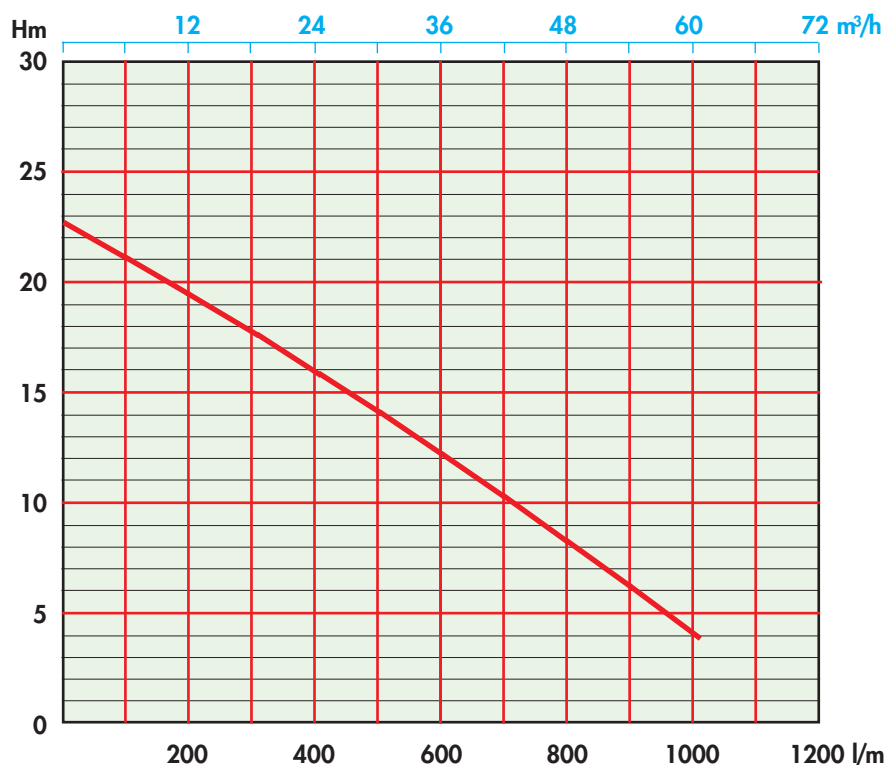

© Descriptions, technical data and features contained in this leaflet are not binding. We reserve the right to make any necessary modifications without prior notice.

