

EVAK STAINOX 5.10

316 SS submersible for dirty water and sewage

Available in 230/1/50 and 400/3/50 the cast 316 stainless steel Stainox submersible pump has been designed for arduous contaminated water and sewage type applications.

It features a vortex impeller providing a 35mm dia. solids handling capability.

- Nominal 0.75kW (1HP) • Klixon Protection
- Nom. 6.0 Amp (230V) - 2.2 Amp (400V)
- 2850 RPM • Oil Chamber with Viton Oil Seal
- Double Mechanical Seal - Ca/Ce+Sic/Sic
- Cast 316 SS construction • Nylon 6 handle
- Sheet 316 Motor Housing • Weight only 18 Kg.
- 10 metre H07RN-F cable as standard
- Models to Max. 30mH/21l/s available to order

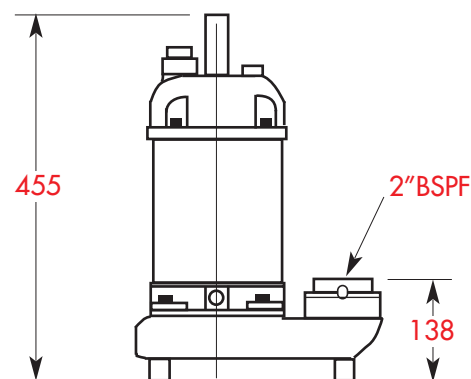
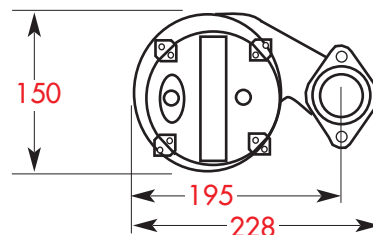
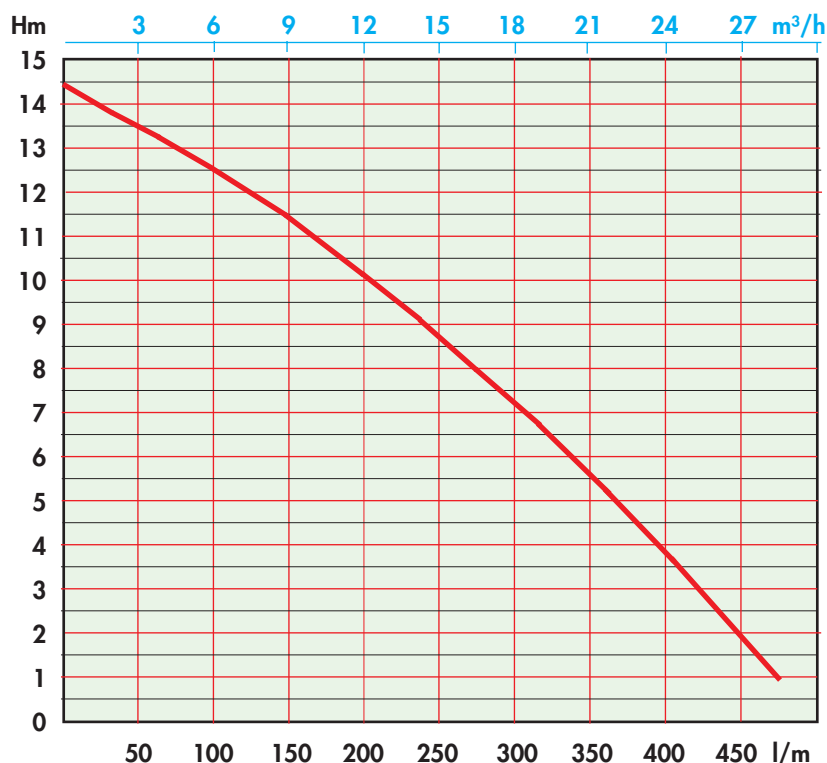

© Descriptions, technical data and features contained in this leaflet are not binding. We reserve the right to make any necessary modifications without prior notice.

