

SIGMA 50-GFRU

the submersible pump for dirty water and sewage

Available as auto or manual versions in 110V and 240V single phase and 415V three phase, Sigma 50-GFRU submersible pumps have been designed for arduous dirty water and sewage type applications.

They feature vortex impellers providing a 30mm dia. solids handling capability.

- Nominal 1.1kW (1.5HP)
- 110V = 16.0Amp
- 240V = 8.0Amp
- 415V = 3.1Amp
- Mechanical seal - Silicon carbide/ceramic
- Cast iron construction
- 10 metre cable as standard
- Optional float switch on single phase models
- Weight 110V = 29kg
240V = 26kg
415V = 24kg
- Suitable for vertical, horizontal or inclined applications

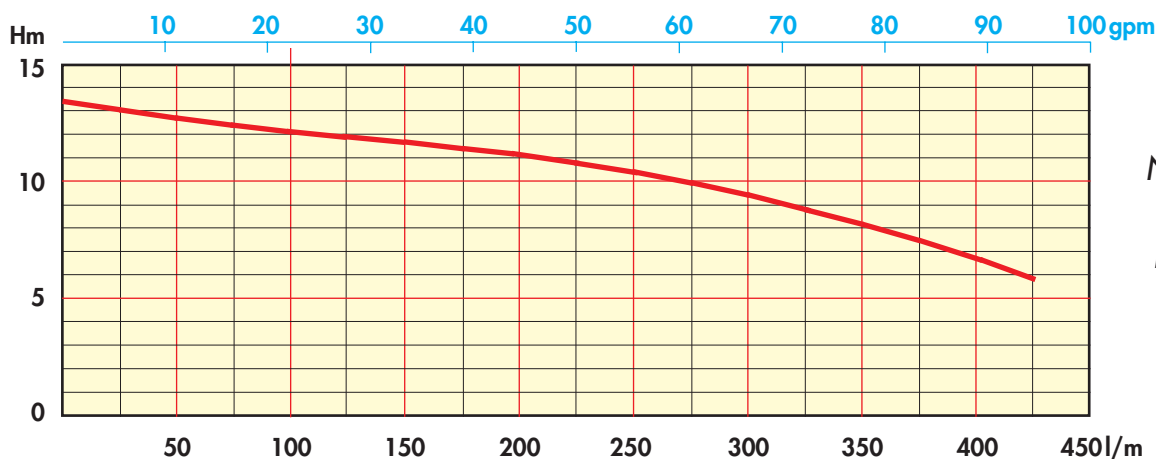
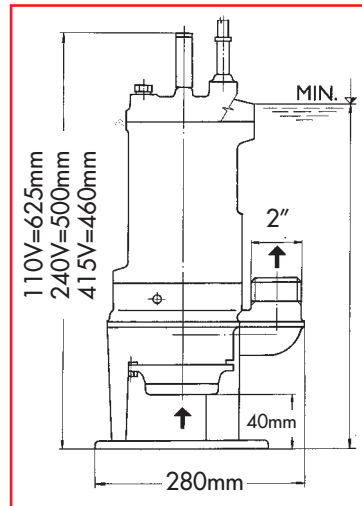

Note:
Not suitable for applications below 5 metre head due to cavitation.

© Descriptions, technical data and features contained in this leaflet are not binding. We reserve the right to make any necessary modifications without prior notice.

