

# KDDF 80 EXPLOSION PROOF PUMPS

## Rated EExdl/II BT6 Dirty Water Submersible Drainers

Designed for explosive risk environments, these EExdl/II BT6 rated submersible drainers handle liquids containing abrasive particles such as sand, coal dust etc. up to a maximum 30% of the pumped liquid mass. Maximum submersion is 10m.

The pumped liquid must have a maximum density of  $1,150\text{kg/m}^3$ ; a maximum grain size of solids 5mm; a maximum temperature of  $40^\circ\text{C}$  and a pH range between 5 and 8.

- Nominal 4.0kW, 400V/3/50 = 7Amp
- Double mechanical seal, oil bath lubricated
- Cast iron construction - 422420
- Abrasion-proof rubber coating on wear parts
- Supplied with 50m of rugged 7 core x 1.5 cable
- Pump weight 56kg

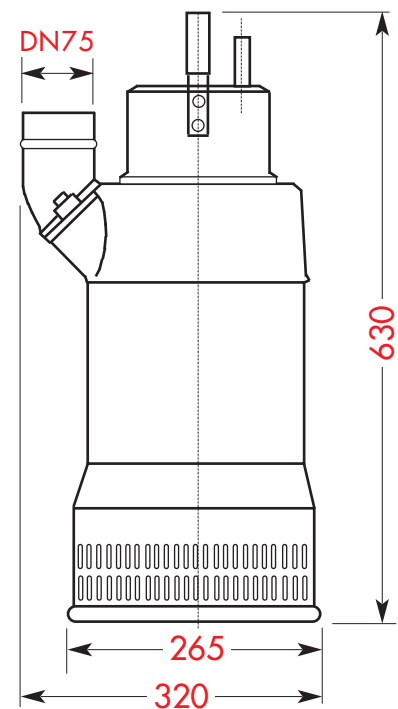
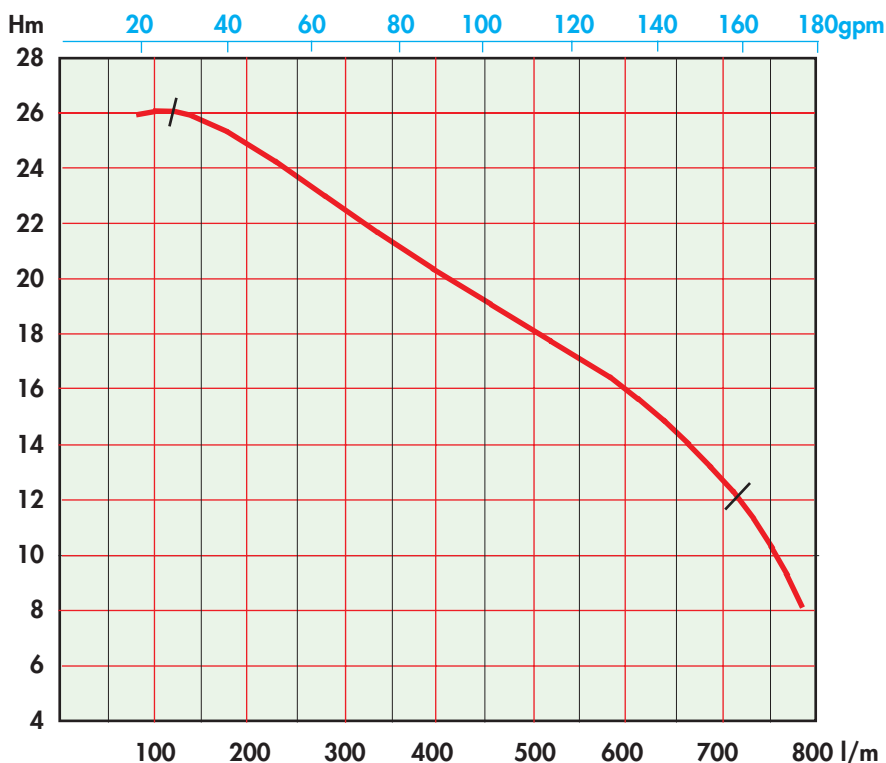

© Descriptions, technical data and features contained in this leaflet are not binding. We reserve the right to make any necessary modifications without prior notice.

