

SIGMA 40-GFZU

Submersible macerator pumps

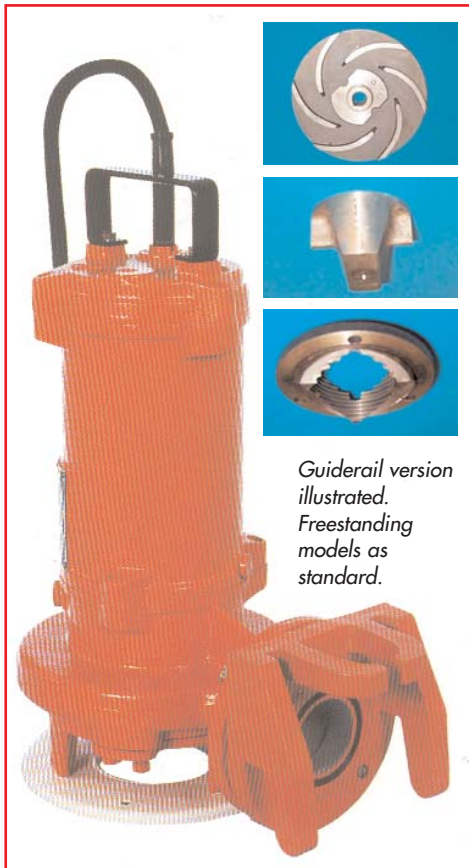

Guiderail version
illustrated.
Freestanding
models as
standard.

Designed to handle raw waste water containing long fibrous material of organic character, these macerator pumps are used mainly in the sewage, agricultural and textile industries. They feature a heavy duty cutter block revolving in a serrated cutter ring, with a close tolerance impeller suitable for continuous operation with pumped media up to a maximum 40°C.

Body, volute and impeller: Cast iron

Cutter block and ring: hardened stainless steel

SiC+Ceramic mechanical seal.

10m cable (H07RN-F) as standard.

Float switch as standard on 230V single phase models.

Contactor/overload supplied with 230V models.

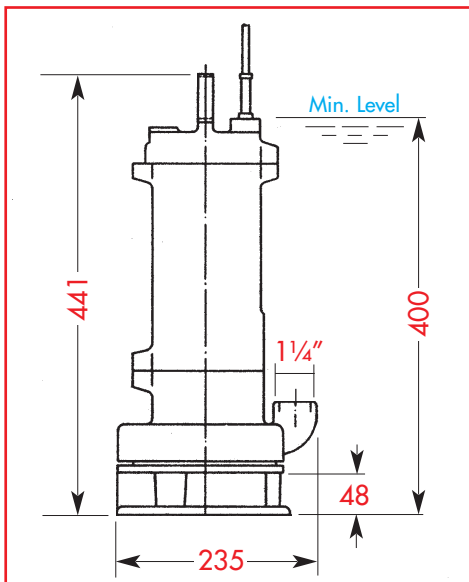
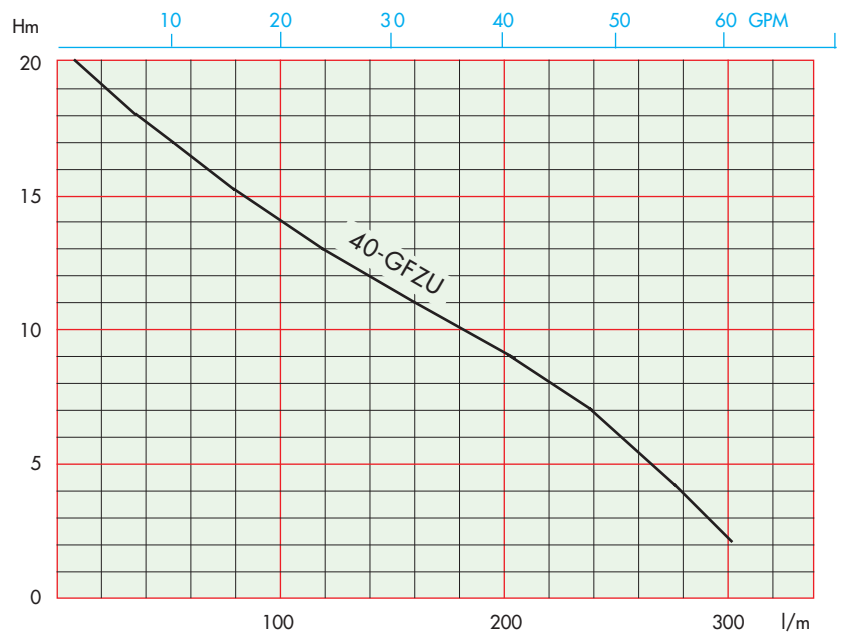

TECHNICAL DATA

MODEL	NOMINAL		NOM Amp	CAPACITOR μF	WEIGHT Kg
	kW	HP			
40-GFZU - 230/1/50	1.1	1.5	7.4	35	24
40-GFZU - 400/3/50	1.1	1.5	2.9	-	24

© Descriptions, technical data and features contained in this leaflet are not binding. We reserve the right to make any necessary modifications without prior notice.

