

SEMISOM SERIES 80 SEWAGE PUMPS

Heavy duty models for 74mm solids handling



A range of heavy duty pumps designed for waste water and sewage applications, combining excellent solids handling characteristics with long service life.

All models are 400/3/50 with 2-pole motors, with the exception of the 1504/80T which has a 1400 rpm 4-pole motor, particularly suited to abrasive media applications.

Tie rods, handle, bolts and motor shaft: Stainless steel.

Cover, body and impeller: Cast iron. Motor cylinder: Steel.

Upper mechanical seal: Graphite and ceramic.

Oil Bath. Lower mechanical seal: Silicon Carbide.

Oil filled motor with water-in-oil sensor and thermal trip.

Max. immersion 20m. Max. 15 starts per hour.

Max. water temp. Continuous: 35°C Intermittent: 45°C

Supplied with 10m cable as standard.

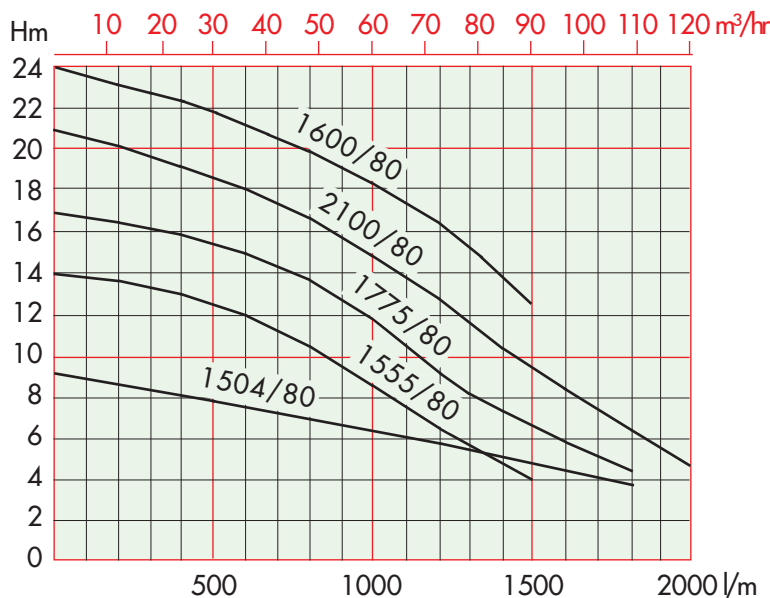
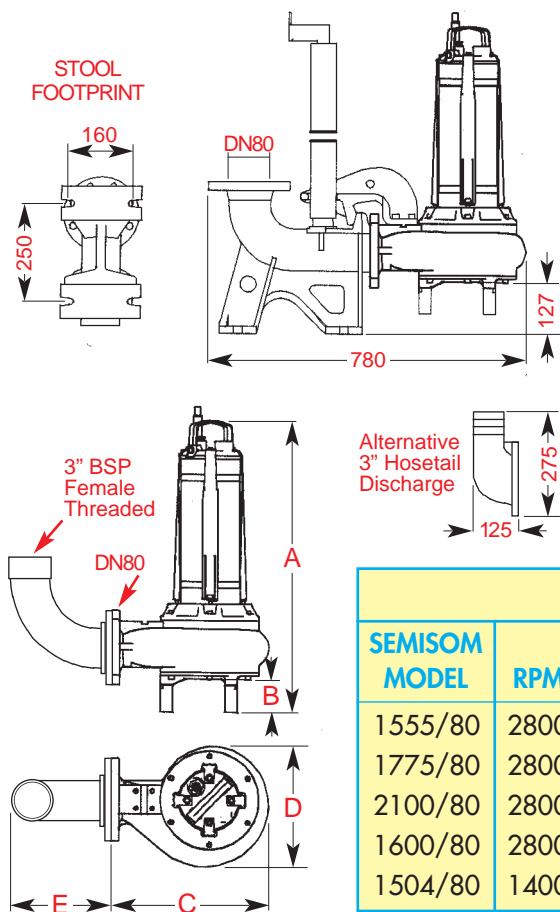

TECHNICAL DATA											
SEMISOM MODEL	RPM	kW		AMP	DIMENSIONS mm					WEIGHT Kg	
		P ₁	P ₂		A	B	C	D	E		Flange
1555/80	2800	5.35	4.0	9.2	703	78	383	295	230	DN80	65.5
1775/80	2800	6.8	5.5	11.9	733	78	383	295	230	DN80	69.0
2100/80	2800	9.0	7.5	16.2	758	78	383	295	230	DN80	71.0
1600/80	2800	9.0	7.5	16.2	758	78	383	295	230	DN80	71.0
1504/80	1400	3.65	2.6	8.2	758	78	383	295	230	DN80	71.0

© Descriptions, technical data and features contained in this leaflet are not binding. We reserve the right to make any necessary modifications without prior notice.

