

SEMISOM 130H

High head submersible pump for dirty water

Available in 110V and 240V single phase and 400V three phase models, Semison 130H submersible pumps have been designed for high head dirty water applications. They feature open channel impellers and provide a 5mm dia. solids handling capability.

- Nominal 1.1kW (1.5HP)
- 110V= 15.1Amp - 230V= 7.6Amp - 400V= 2.9Amp
- Mechanical seal and lip seal
- Coolant filled motor
- Cast iron/Stainless construction
- 10 metre cable as standard (20m on 110V)
- Thermal reset capacitor box on 1 phase models
- Optional float switch on 1 phase models
- Weight 22 Kg. • Guiderail kits available

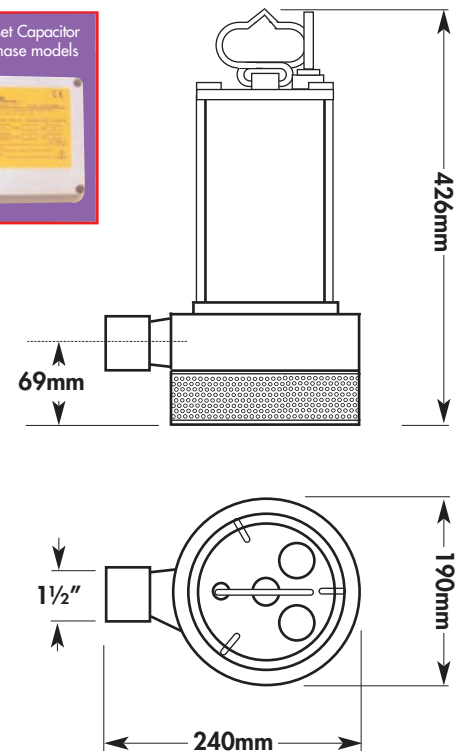
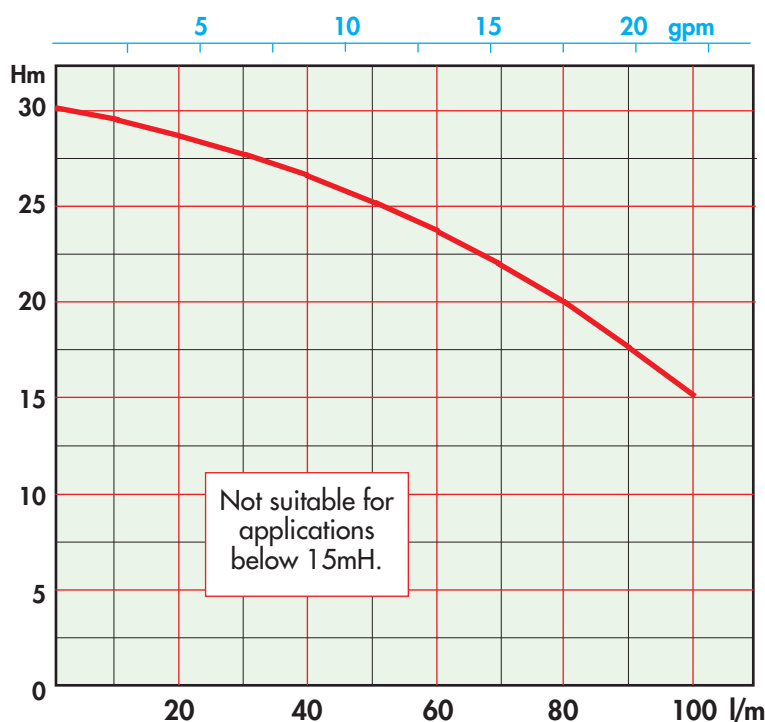

© Descriptions, technical data and features contained in this leaflet are not binding. We reserve the right to make any necessary modifications without prior notice.

