

EVAK RESIDOX

Residue drainage pump for pumping down to 1mm

Available in both 110V and 230V single phase models, the Residox 400 residue drainage pump is designed for handling nuisance water found on flat surfaces and will pump down to 1mm. It features a stainless steel outer cover and handle, with NBR suction base, FC20 cast iron pump housing and ADC12 alloy motor housing and seal casing. The highly abrasion resistant *Hytre* vortex impeller reduces wear and maintains reliability.

- Nominal 400W (0.5HP) • 2850 RPM
- 110V = 6Amp - 230V = 3Amp
- Double mechanical seal in oil chamber - SIC/SIC
- Auto reset thermal protector • Internal capacitor
- 10 metre H07RN-F cable as standard
- Discharge 2" Hosetail
- Weight only 12 Kg.

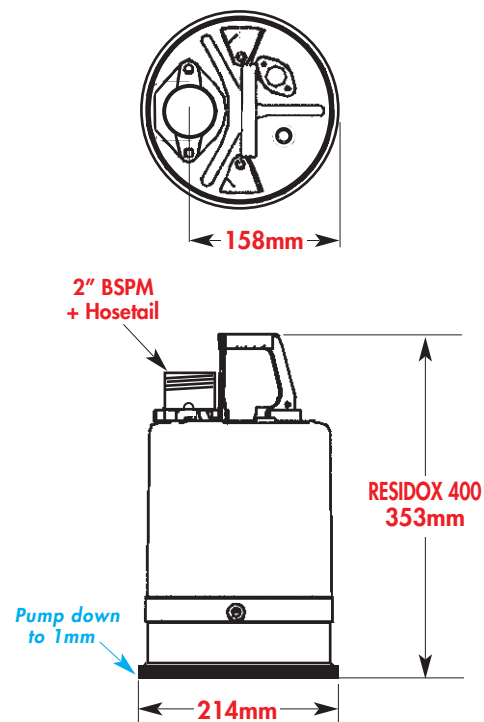
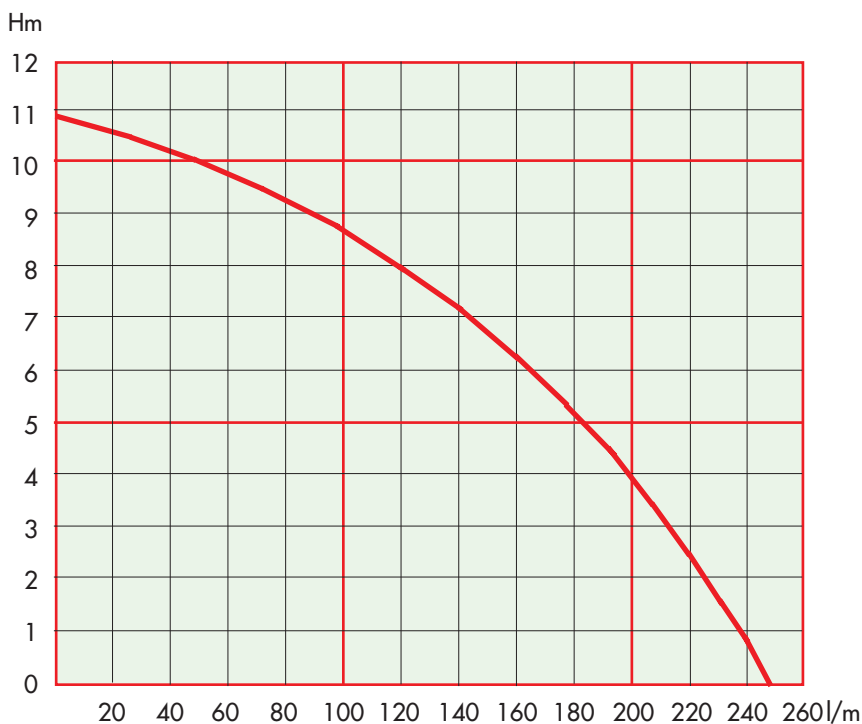

© Descriptions, technical data and features contained in this leaflet are not binding. We reserve the right to make any necessary modifications without prior notice.

