

MAXI HON

Single channel impeller for 78mm solids handling

The 400/3/50 Maxi HON submersible is designed for heavy duty applications with screened waste or drainage water containing solids in suspension up to 78mm dia at temperatures up to 40°C.

It features a single channel impeller designed for high hydraulic efficiency mounted on a reduced length shaft.

- G250 cast iron construction
- Double Mechanical seal - silicon carbide/carbide
- O-rings in Nitrile
- Oil chamber
- Asynchronous 1450 rpm motor suitable for >15 starts per hour
- 10 metres Neoprene 12G1.5 HO7RN-F cable as standard
- Built-in thermal protection and humidity probe
- Freestanding and Guiderail options available.

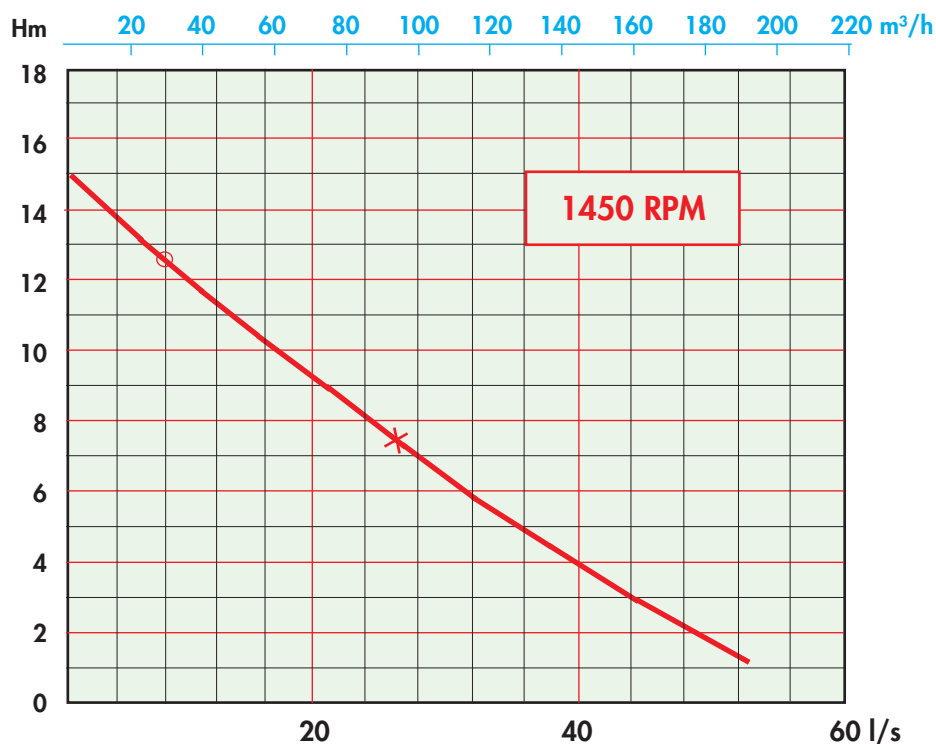

MODEL	Nominal kW	Nom. Amps	Weight Kg	Best Efficiency		
				kW	mH	m ³ /hr
MAXI HON	3.8	8.0	110	3.7	7.4	92.0

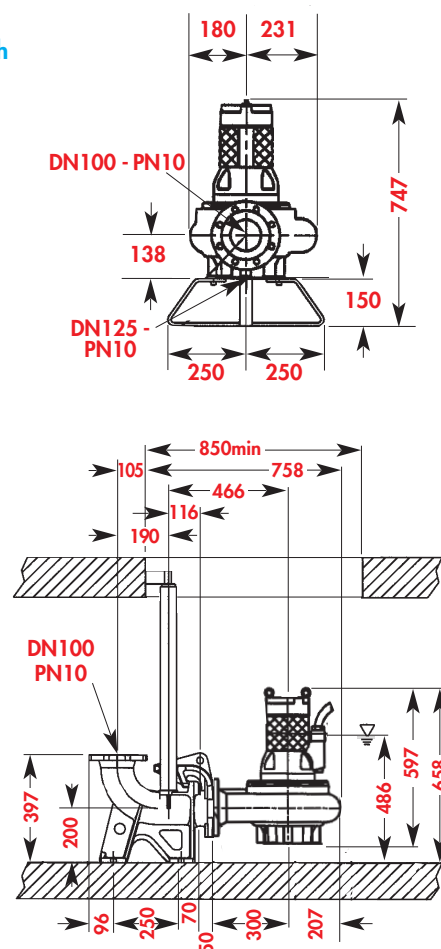

© Descriptions, technical data and features contained in this leaflet are not binding. We reserve the right to make any necessary modifications without prior notice.

