

MAXI HK

Single channel impeller for 90mm solids handling

The 400/3/50 Maxi HK submersible is designed for heavy duty applications with screened waste or drainage water of maximum density 1.2kg/dm^3 , containing solids in suspension up to 90mm dia at temperatures up to 40°C . It features a single channel impeller designed for high hydraulic efficiency mounted on a reduced length shaft.

- G250 cast iron construction
- Mechanical seal - silicon carbide/carbide
- Lip seal and O-rings in Nitrile
- Oil chamber
- Asynchronous 1450 rpm motor suitable for >15 starts per hour
- 10 metres Neoprene HO7RN-F cable as standard
- Freestanding, Guiderail and Eex options available.

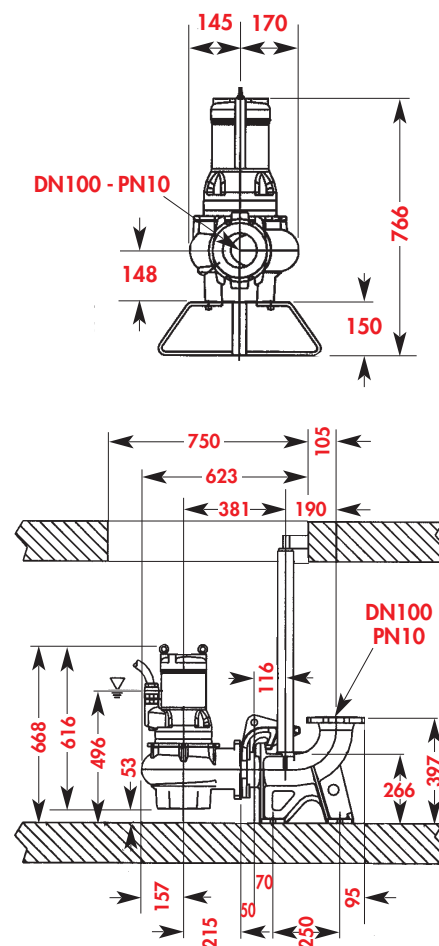
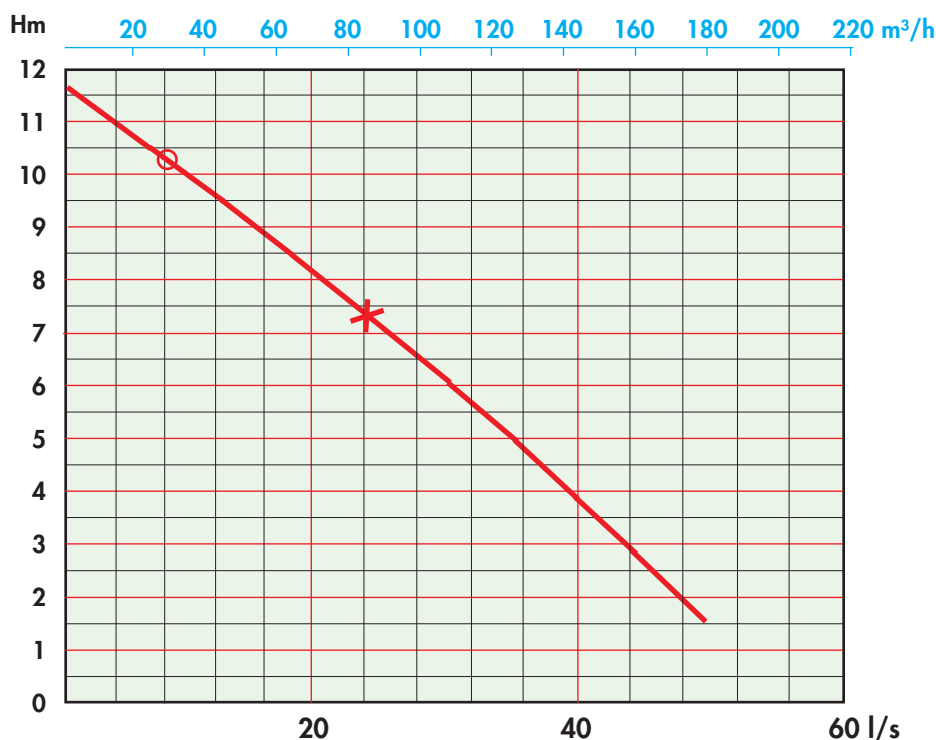

MODEL	Nom. kW	Nom. Amps	Weight Kg	Best Efficiency		
				kW	mH	m³/hr
MAXI HK	3.8	8.0	82	3.1	7.3	85.0

© Descriptions, technical data and features contained in this leaflet are not binding. We reserve the right to make any necessary modifications without prior notice.

