

# EVAK HIPPO 80 SERIES

## 230/1/50 - 3" Free Passage for Wastewater and Sewage

These 230/1/50 pumps have been designed specifically for heavy duty wastewater and sewage type applications. They feature recessed vortex impellers providing a 3" solids handling capability. DN80 discharge flange.

- Manual or Float Switch options available
- Hippo 80-150 = 1.1kW - FLC = 9.8 Amp - Weight 31kg
- Hippo 80-200 = 1.5kW - FLC = 11.2 Amp - Weight 33kg
- Internal Capacitor: 30 $\mu$ F 1.1kW, 40 $\mu$ F 1.5kW.
- Double mechanical seal Eagle Burgmann  
Upper: Ca/Ce - Lower Sic/Sic
- Oil bath with NBR oil seal • Built in Thermal protector
- Cast Iron FC 200/Stainless Steel construction
- Maximum operating temperature 40°C
- Maximum 20 Starts per hour.
- 10m H07RN-F cable as standard
- Guiderail option is available.

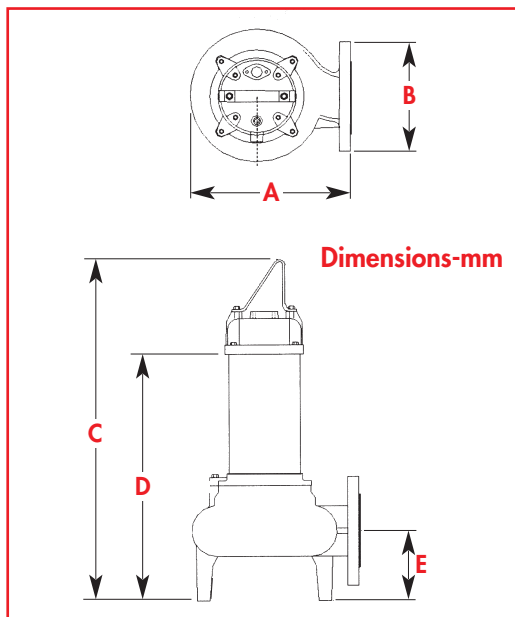

MODEL	A	B	C	D	E
HIPPO 80-150	300	200	613	440	130
HIPPO 80-200	300	200	635	460	130

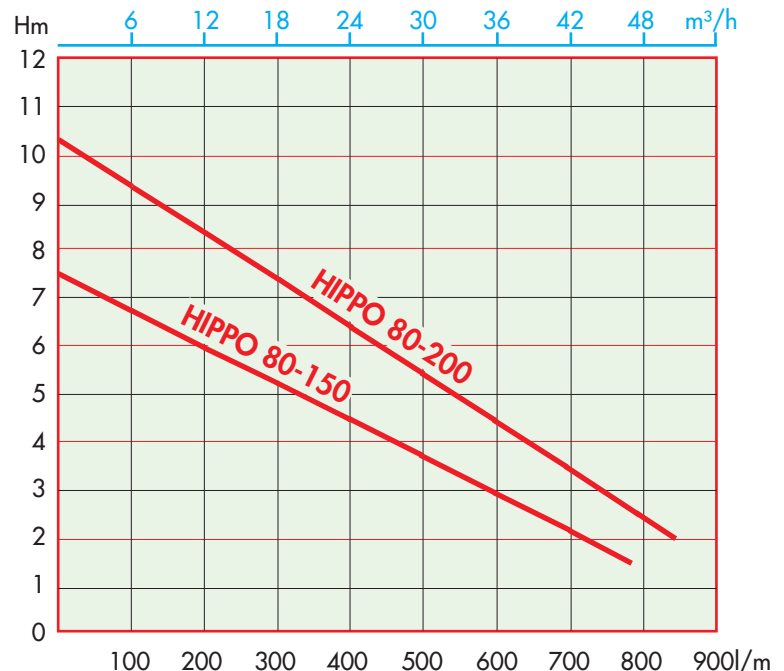

© Descriptions, technical data and features contained in this leaflet are not binding. We reserve the right to make any necessary modifications without prior notice.

