

EVAK HIPPO 65 SERIES

230/1/50 - 2½" Free Passage for Wastewater and Sewage

These 230/1/50 pumps have been designed specifically for heavy duty wastewater and sewage type applications. They feature recessed vortex impellers providing a 2½" solids handling capability. DN65 discharge flange.

- Manual or Float Switch options available
- Hippo 65-150 = 1.1kW - FLC = 9.5 Amp - Weight 28kg
- Hippo 65-200 = 1.5kW - FLC = 11 Amp - Weight 30kg
- Internal Capacitor: 30µF 1.1kW, 40µF 1.5kW.
- Double mechanical seal Eagle Burgmann
Upper: Ca/Ce - Lower Sic/Sic
- Oil bath with NBR oil seal • Built in Thermal protector
- Cast Iron FC 200/Stainless Steel construction
- Maximum operating temperature 40°C
- Maximum 20 Starts per hour.
- 10m H07RN-F cable as standard
- Guiderail option is available.

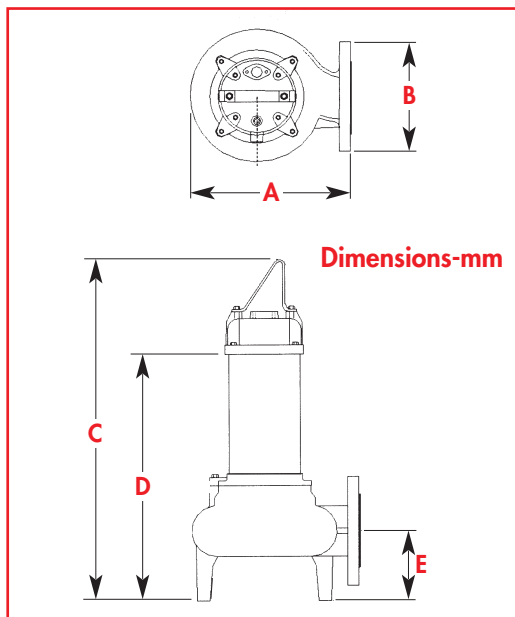

| MODEL | A | B | C | D | E |
|--------------|-----|-----|-----|-----|-----|
| HIPPO 65-150 | 270 | 190 | 580 | 405 | 105 |
| HIPPO 65-200 | 270 | 190 | 600 | 425 | 105 |

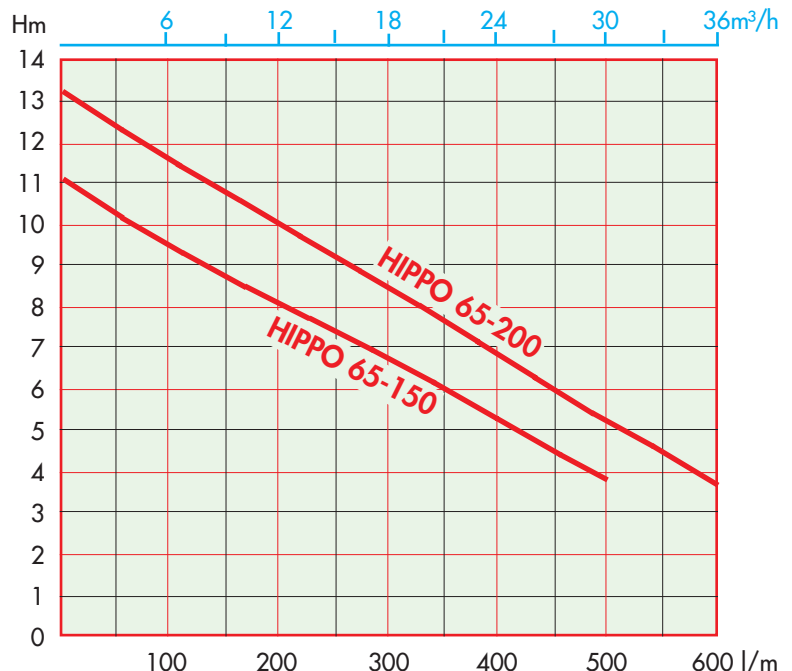

© Descriptions, technical data and features contained in this leaflet are not binding. We reserve the right to make any necessary modifications without prior notice.

