

# EVAK HIPPO 200

## heavy duty submersible pump for dirty water and sewage

Available in 230V single phase and 400V three phase models, Hippo 200 submersible pumps have been designed for arduous dirty water and sewage type applications. They feature recessed vortex impellers providing a 50mm dia. solids handling capability.

- Nominal 1.5kW (2.0HP)
- 230V = 12.0Amp - 400V = 3.4Amp
- Thermal protector 1~ • Overload protector 3~
- Double mechanical seal (Ca/Ce + Sic/Sic)
- Oil bath with oil seal
- Cast iron/Stainless steel construction
- Maximum operating temperature 40°C
- 10m H07RN-F cable as standard
- Float switch on single phase models
- Weight only 26 Kg.

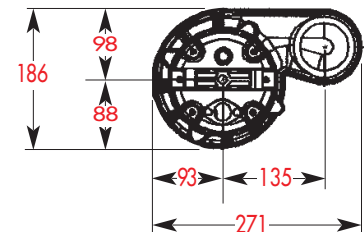
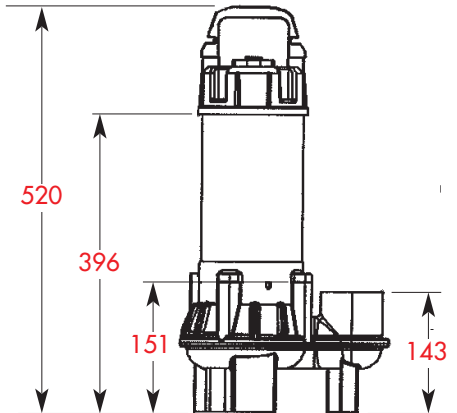
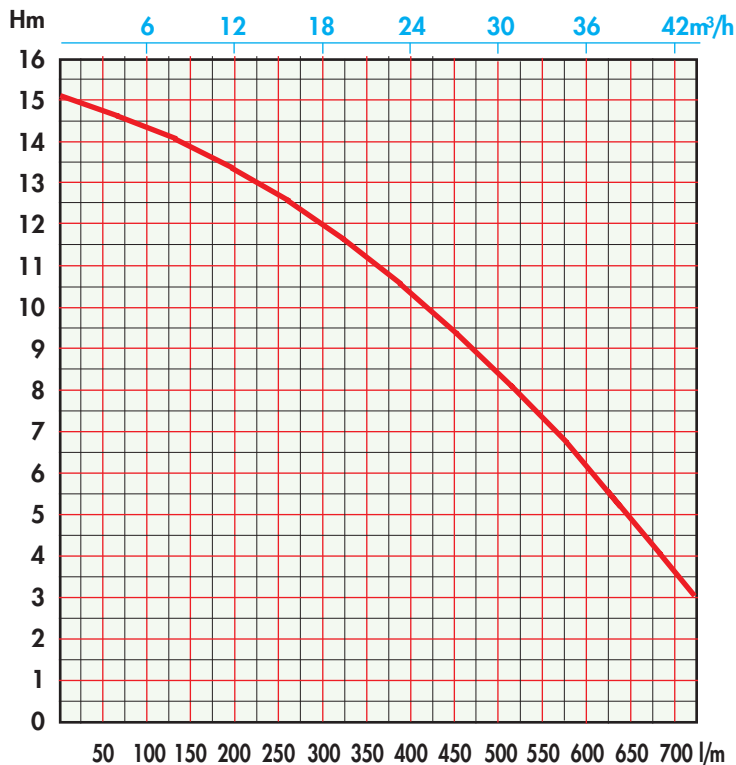
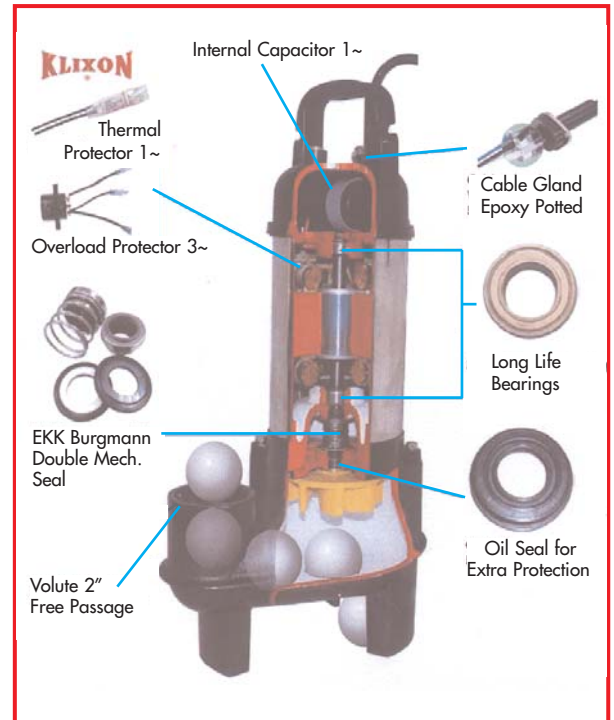

© Descriptions, technical data and features contained in this leaflet are not binding. We reserve the right to make any necessary modifications without prior notice.

