

EVAK DRAINOX

heavy duty site drainage pumps with Hytrel impellers

Available in 110V and 230V 1-phase and 400V 3-phase models, Drainox drainage pumps are designed for arduous site drainage applications. They feature stainless steel strainer base, outer cover and handle, with FC20 cast iron pump housing and ADC12 alloy motor housing and seal casing. The highly abrasion resistant Hytrel vortex impeller reduces wear and maintains reliability.

- Drainox 400 - 400W (0.5HP) • 2850 RPM
110V = 6Amp - 230V = 4Amp - 400V = 2Amp
- Drainox 750 - 750W (1HP) • 2850RPM
110V = 11Amp - 230V = 5.4Amp - 400V = 2.4Amp
- Double mechanical seal in oil chamber - SIC/SIC
- Auto reset thermal protector • Internal capacitor
- 10 metre H07RN-F cable as standard
- Discharge 2" BSP Female/Hosetail
- 110V Auto or Manual - 230V Auto - 400V Manual
- Weight: Drainox 400 = 13kg - Drainox 750 = 16kg

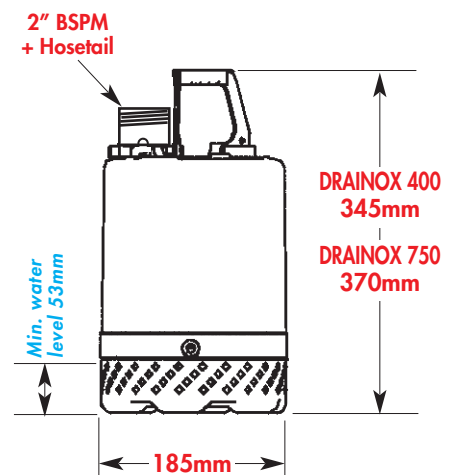
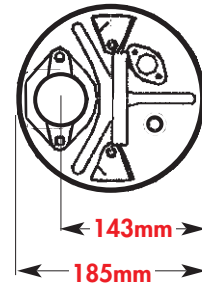
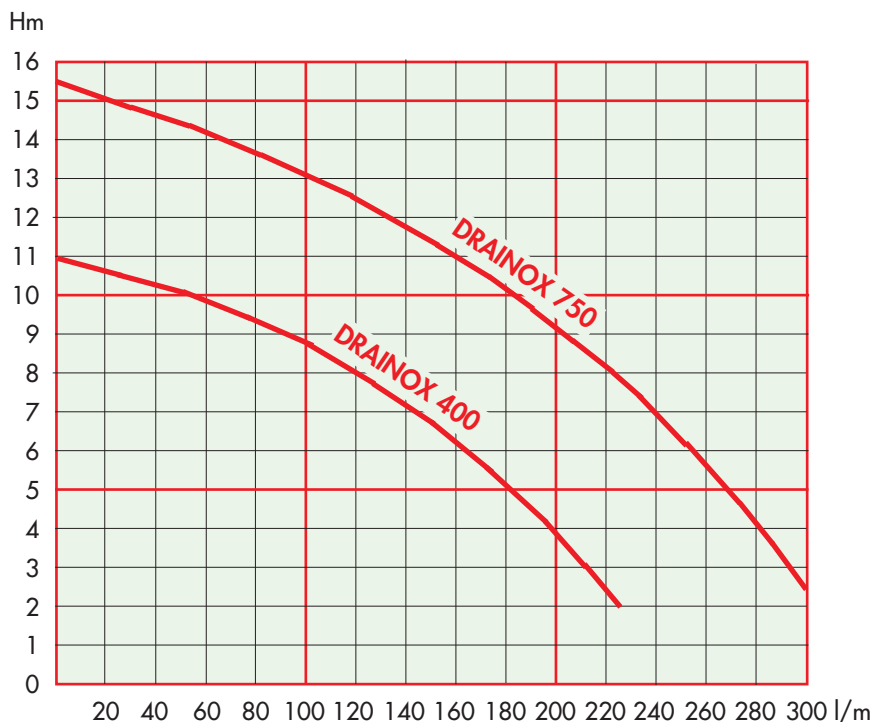

© Descriptions, technical data and features contained in this leaflet are not binding. We reserve the right to make any necessary modifications without prior notice.

