

EVAK DRAINOX 1500

heavy duty site drainage pumps with Hytrel impellers

Available in both 230/1/50 and 400/3/50 models, Drainox 1500 drainage pumps are designed for arduous site drainage applications. They feature stainless steel strainer base, outer cover and handle, FC20 cast iron pump housing, ADC12 alloy motor housing and seal casing and A356 aluminium oil chamber. The highly abrasion resistant *Hytrel* vortex impeller reduces wear and maintains reliability.

- Drainox 1500 - 1.5kW (2.0HP) • 2850 RPM
230V = 12Amp - 400V = 3.5Amp
- Double mechanical seal in oil chamber -
Upper CA/CE, Lower SIC/SIC
- Auto reset thermal protector • Internal capacitor
- 10 metre H07RN-F cable as standard
- Discharge 2" BSPM/Hosetail
- 230V Auto or Manual - 400V Manual
- Weight: Drainox 1500 = 24kg

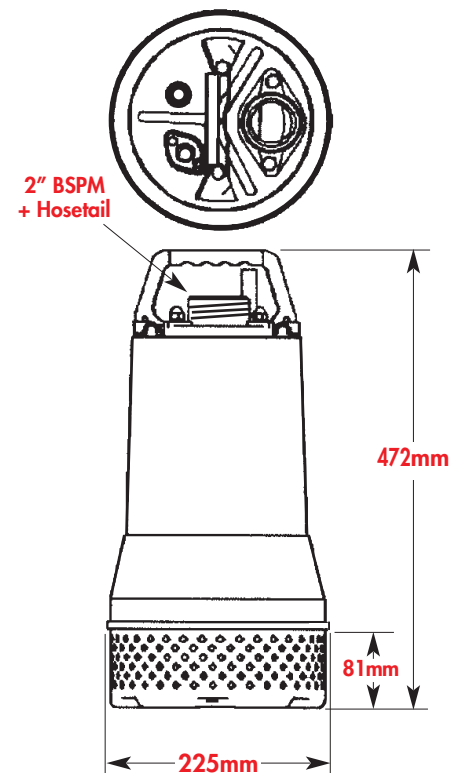
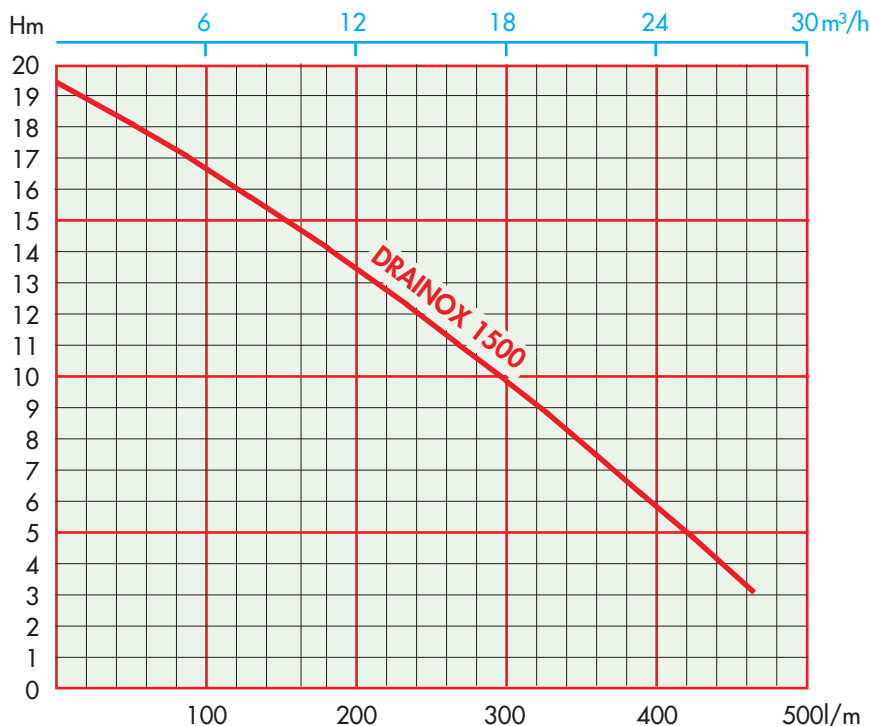

© Descriptions, technical data and features contained in this leaflet are not binding. We reserve the right to make any necessary modifications without prior notice.

