

# PUMP FLOAT SWITCH ALARM UNIT

## Flashing light with 25 hour battery back-up

This simple to install unit is designed for visual alarm of pump plant failure, even in the case of power cut. It features an LED red flashing light with a battery back-up time of approx. 25 hours. A powerful audible version is also available.



### SPECIFICATION

Mains supply: 230V/1/50Hz

Box Size: 220x150x75mm

Light Box Size: 105x105x90mm

Cable: 10m of 2x1mm<sup>2</sup>

LED Light: Red (Alt. Amber/Blue)

Battery: NiCd - 12Vdc - 0.6Ah

Restoration time: Approx 12 hrs

Battery operating time:

Approx. 25 hrs.

Three-Way switch:

ON: Float switch alarm

OFF: Alarm off

TEST: Checks function

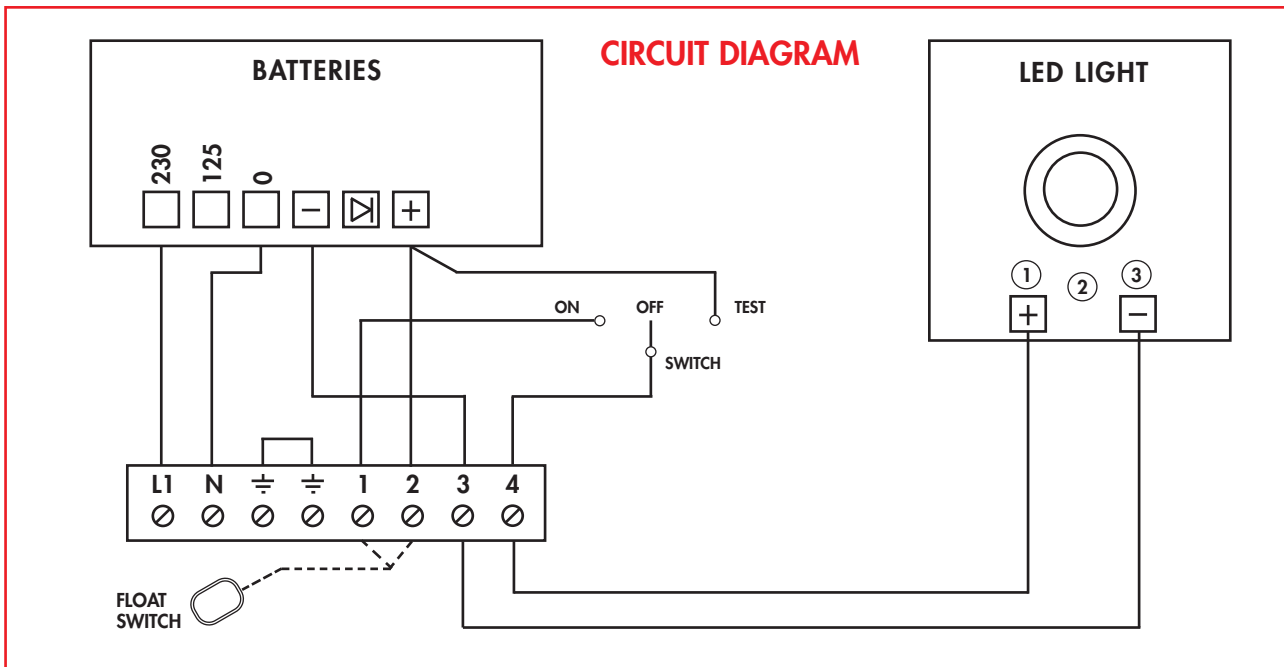

© Descriptions, technical data and features contained in this leaflet are not binding. We reserve the right to make any necessary modifications without prior notice.

