

# PUMP FLOAT SWITCH ALARM UNIT

## Audible with 12 hour battery back-up

This simple to install unit is designed for audible/visual alarm of pump plant failure, even in the case of power cut. It features a 102dB/1m alarm with a battery back-up time of approximately 12 hours. *A powerful beacon version is also available.*



### SPECIFICATION

Mains supply: 230V/1/50Hz

Size: 190 x 140 x 70mm

Weight: 0.9kg

Battery: NiCd - 6Vdc - 0.5Ah

Alarm: 102dB/1m

35/6mA/V

F=2700Hz

Visual alarm: LED D5

Restoration time: Approx 12 hrs

Battery operating time:

Approx. 12 hrs.

Three-Way switch:

ON: Float switch alarm

OFF: Alarm off

TEST: Checks function

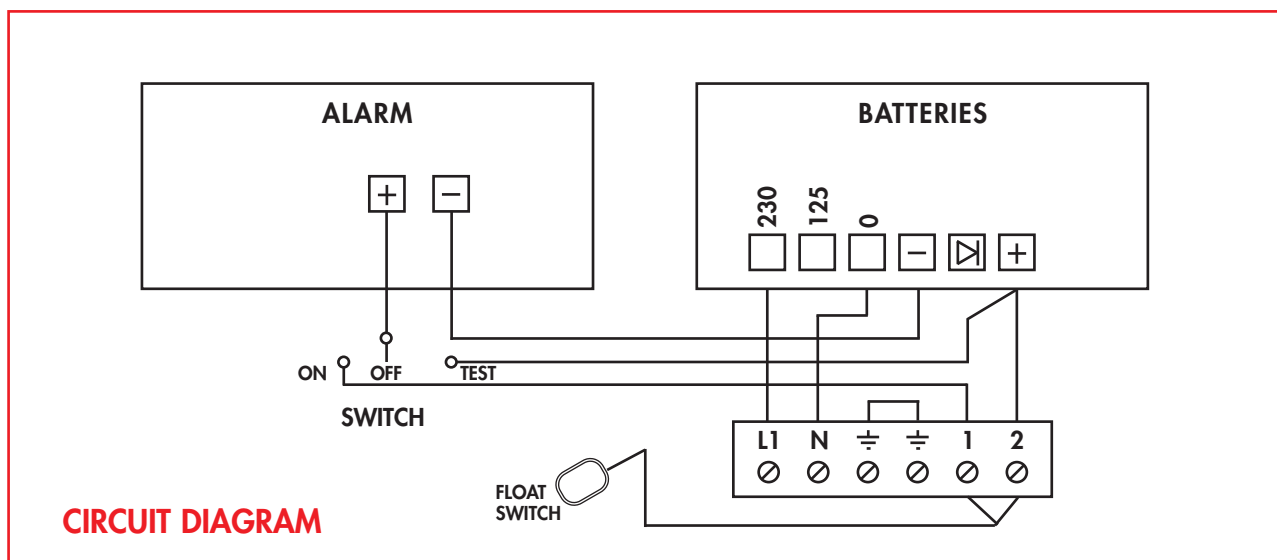

© Descriptions, technical data and features contained in this leaflet are not binding. We reserve the right to make any necessary modifications without prior notice.

